



## WATER COOLERS

\*Price Change

### WALL MOUNT BARRIER-FREE WATER COOLER

- WATERWAYS LEAD-FREE IN MATERIALS & CONSTRUCTION • STAINLESS STEEL TOP
- TWO-TONE GRAY POLYMER CABINET WITH SOFTLY ROUNDED EDGES • WALL MOUNT
- SELF-CLOSING LIGHT-TOUCH PUSH BARS • TWO STREAM ANTI SQUIRT BUBBLER
- REFRIGERANT R134A • LIMITED 5 YEAR WARRANTY

SSC No.	Manuf No.	Rated GPH Cooled to 50° F*	Watts Per Hr	115V /60Hz Amps	Compr. H.P.	Wgt	Price Each
18A 3000	<b>HTV8-Q</b>	7.6	360	4.5	1/8	51 Lbs	\$ 596.58 *

\*90° F Ambient Air Temperature



#### FRONT VIEW/WALL LAYOUT

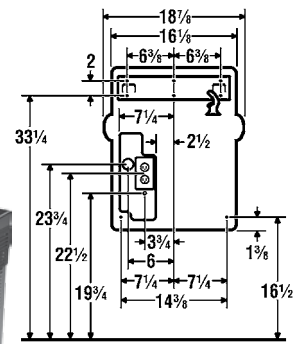

For More Information On These Products Or On Products Not Listed,  
Call *Salina Supply Company* At (785) 823-2221

### BI-LEVEL BARRIER-FREE WATER COOLER

- WATERWAYS LEAD-FREE IN MATERIALS & CONSTRUCTION • STAINLESS STEEL TOP
- TWO-TONE GRAY POLYMER CABINET WITH SOFTLY ROUNDED EDGES • WALL MOUNT
- SELF-CLOSING LIGHT-TOUCH PUSH BARS • TWO STREAM ANTI SQUIRT BUBBLER
- REFRIGERANT R134A • LIMITED 5 YEAR WARRANTY

SSC No.	Manuf No.	Rated GPH Cooled to 50° F*	Watts Per Hr	115V /60Hz Amps	Compr. H.P.	Wgt	Price Each
18A 3050	<b>HTV8BL-Q</b>	7.2	575	5	1/8	78 Lbs	\$ 1,059.35 *

\*90° F Ambient Air Temperature



#### FRONT VIEW/WALL LAYOUT

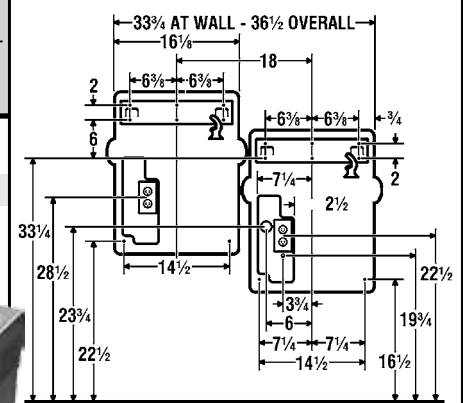

### FOUNTAIN PRESSURE REGULATOR

- USE FOR IN-LINE INSTALLATIONS BETWEEN STOP & OUTLET • 3/8" IPS

Manuf No.	Size	Price Each
<b>60-01980-5</b>	3/8	Bright Chrome Finish \$ 79.82



## ELKAY WATER COOLERS

\* Price Change  
\*\* New Product

### VERSATILE BI LEVEL WALL MOUNT WATER COOLER

LIGHT GRAY GRANITE • SELF-CLOSING EASY TOUCH CONTROLS ON FRONT & SIDES • FLEXI-GUARD SAFETY BUBBLER

MODEL	RATED CAPACITY*	POWER	FULL LOAD AMPS	WATTS RATED
EZSTL8LC	8 GPH	115V/60Hz	4.0	370

SSC No.	Manuf No.	Length	Width	Height	Wgt	Price Each
18A 1310	<b>EZSTL8LC</b>	36 <sup>3</sup> / <sub>4</sub> "	19"	25 <sup>5</sup> / <sub>16</sub> "	72 Lbs	\$ 968.45 *

\*BASED ON 80° F INLET WATER & 90° F AMBIENT AIR TEMP FOR 50° F CHILLED DRINKING WATER



### BARRIER FREE WALL MOUNT WATER COOLER

WALL MOUNT • LIGHT GRAY GRANITE • WRAP AROUND PRESS BAR • FLEXI-GUARD SAFETY BUBBLER • NON-FILTERED

MODEL	RATED CAPACITY*	POWER	FULL LOAD AMPS	WATTS RATED
EZS8L	8 GPH	115V/60Hz	4.0	370

SSC No.	Manuf No.	Length	Width	Height	Wgt	Price Each
18A 2000	<b>EZS8L</b>	18 <sup>3</sup> / <sub>8</sub> "	19"	19 <sup>13</sup> / <sub>16</sub> "	51 Lbs	\$ 599.32 *

\*BASED ON 80° F INLET WATER & 90° F AMBIENT AIR TEMP FOR 50° F CHILLED DRINKING WATER



### BARRIER FREE WALL MOUNT WATER COOLER

WALL MOUNT • LIGHT GRAY GRANITE • FLEXI-GUARD SAFETY BUBBLER • ONE PIECE BACKSPLASH & BASIN

MODEL	RATED CAPACITY*	POWER	FULL LOAD AMPS	WATTS RATED
EHFSA8L	7.6 GPH	115V/60Hz	4.0	370

SSC No.	Manuf No.	Length	Width	Height	Wgt	Price Each
18A 2840	<b>EHFSA8L</b>	18"	18 <sup>3</sup> / <sub>4</sub> "	23 <sup>7</sup> / <sub>8</sub> "	70 Lbs	\$ 947.32 *

\*BASED ON 80° F INLET WATER & 90° F AMBIENT AIR TEMP FOR 50° F CHILLED DRINKING WATER



### ENHANCED EZH2O BOTTLE FILLING STATION & COOLER

WALL MOUNT • LIGHT GRAY GRANITE • SINGLE STATION • BOTTLE FILLER • SENSOR-ACTIVATED BOTTLE FILLER

MODEL	RATED CAPACITY*	POWER	FULL LOAD AMPS	WATTS RATED	FILL RATE
EZS8WSLK	8 GPH	115V/60Hz	6.0	370	QUICK

SSC No.	Manuf No.	Length	Width	Height	Wgt	Price Each
18A 2010	<b>EZS8WSLK</b>	18 <sup>3</sup> / <sub>8</sub> "	19"	39 <sup>1</sup> / <sub>16</sub> "	82 Lbs	\$ 1,395.77 **

\*BASED ON 80° F INLET WATER & 90° F AMBIENT AIR TEMP FOR 50° F CHILLED DRINKING WATER



### ENHANCED EZH2O BOTTLE FILLING STATION, COOLER & FILTER

WALL MOUNT • LIGHT GRAY GRANITE • SINGLE STATION • BOTTLE FILLER • FILTER • SENSOR-ACTIVATED BOTTLE FILLER

MODEL	RATED CAPACITY*	POWER	FULL LOAD AMPS	WATTS RATED	FILL RATE
LZS8WSLP	8 GPH	115V/60Hz	5.0	370	1.1 GPM

SSC No.	Manuf No.	Length	Width	Height	Wgt	Price Each
18A 2030	<b>LZS8WSLP</b>	18 <sup>3</sup> / <sub>8</sub> "	19"	39 <sup>7</sup> / <sub>16</sub> "	85 Lbs	\$ 1,515.47 **

\*BASED ON 80° F INLET WATER & 90° F AMBIENT AIR TEMP FOR 50° F CHILLED DRINKING WATER



### LEGACY FLOOR MODEL WATER COOLER

FREE STANDING • LIGHT GRAY GRANITE • FLEXI-GUARD SAFETY BUBBLER • NON-FILTERED • REMOVABLE FRONT PANEL

MODEL	RATED CAPACITY	POWER	FULL LOAD AMPS	WATTS RATED
EFA8	7.6 GPH	115V/60Hz	4.0	370

SSC No.	Manuf No.	Length	Width	Height	Wgt	Price Each
18A 2710	<b>EFA8</b>	18"	14 <sup>1</sup> / <sub>2</sub> "	41 <sup>1</sup> / <sub>2</sub> "	71 Lbs	\$ 1,223.03

\*BASED ON 80° F INLET WATER & 90° F AMBIENT AIR TEMP FOR 50° F CHILLED DRINKING WATER

EFA8



### SPACE-ETTE FLOOR MODEL WATER COOLER

FLUSH TO WALL INSTALLATION • LIGHT GRAY GRANITE • SLIM PROFILE • FLEXI-GUARD BUBBLER • NON-FILTERED

MODEL	RATED CAPACITY	POWER	FULL LOAD AMPS	WATTS RATED
FD7003	3 GPH	115V/60Hz	3.5	230

SSC No.	Manuf No.	Length	Width	Height	Wgt	Price Each
18A 2880	<b>FD7003</b>	12"	12"	38"	54 Lbs	\$ 754.80

\*BASED ON 80° F INLET WATER & 90° F AMBIENT AIR TEMP FOR 50° F CHILLED DRINKING WATER

FD7003